

Lightning Link Plans (for the AR-15 rifle)

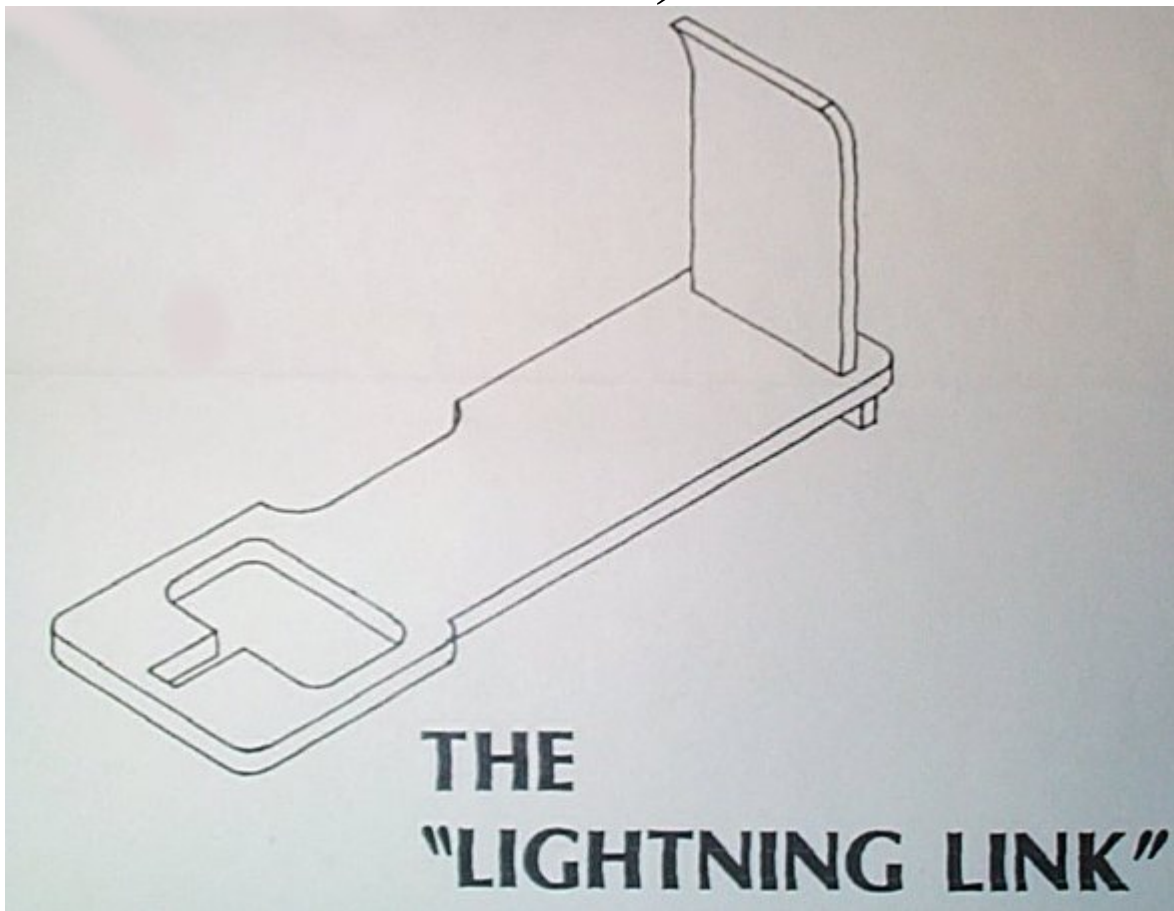

The parts for the Lightning Link can be made from tool steel, machined with great precision, hardened and tempered with loving care, the polished to a high gloss that your mother would be proud of. On the other hand, using only a couple of pieces of power hacksaw blade to make the parts from, a dremel tool, hand drill and one or two files to do the work, you can cut out the Lightning Link in about an hour.

The first description will make a link that you could most likely pass on to your great grandkids. The second may not last that long, but I know of one made from mild steel, that has never been hardened or tempered. It's been used to fire over 5,000 rounds, and still going strong. All that ever goes wrong with it is the part of the bolt carrier hits gets peened over after about five or six hundred rounds. When that happens, the woman that owns it drops it out of the gun, puts it on the rear bumper of her jeep and beats it back in shape with a rock. She's then back in business for a few hundred more rounds.

The only complaint I've ever heard about the Lightning Link is it converts the firearm to full auto only. I can't see that's a problem. No one says you have to hold the trigger down until the magazine's empty. I've found with a little practice it's easy to fire two shot bursts using the Link.

Also keep in mind; that it takes only about ten seconds to install the Lightning Link in a standard unaltered AR-15, and only about six seconds to remove it. Going from semi-auto to full and back to semi is only a matter of seconds.

THE WAY IT WORKS

In normal semi-auto operation the hammer is cocked by a rearward movement of the bolt carrier, as the carrier moves forward, the hammer is caught and held in the cocked position by the sear located on the forward part of the trigger catching in the sear notch, on the hammer. If you hold the trigger after a shot's fired the sear will not catch in the hammer's sear notch when the hammer cocks because the sear is depressed below the arc of the hammer notch.

What happens is because the trigger is being held back, the disconnecter hook is tipped forward and in position to catch the hammer, stopping it from following the bolt carrier forward. When the trigger is released, it allows the hammer to slip from under the disconnecter hook and be caught by the trigger sear in the hammer sear notch. Making it necessary to pull the trigger for each shot.

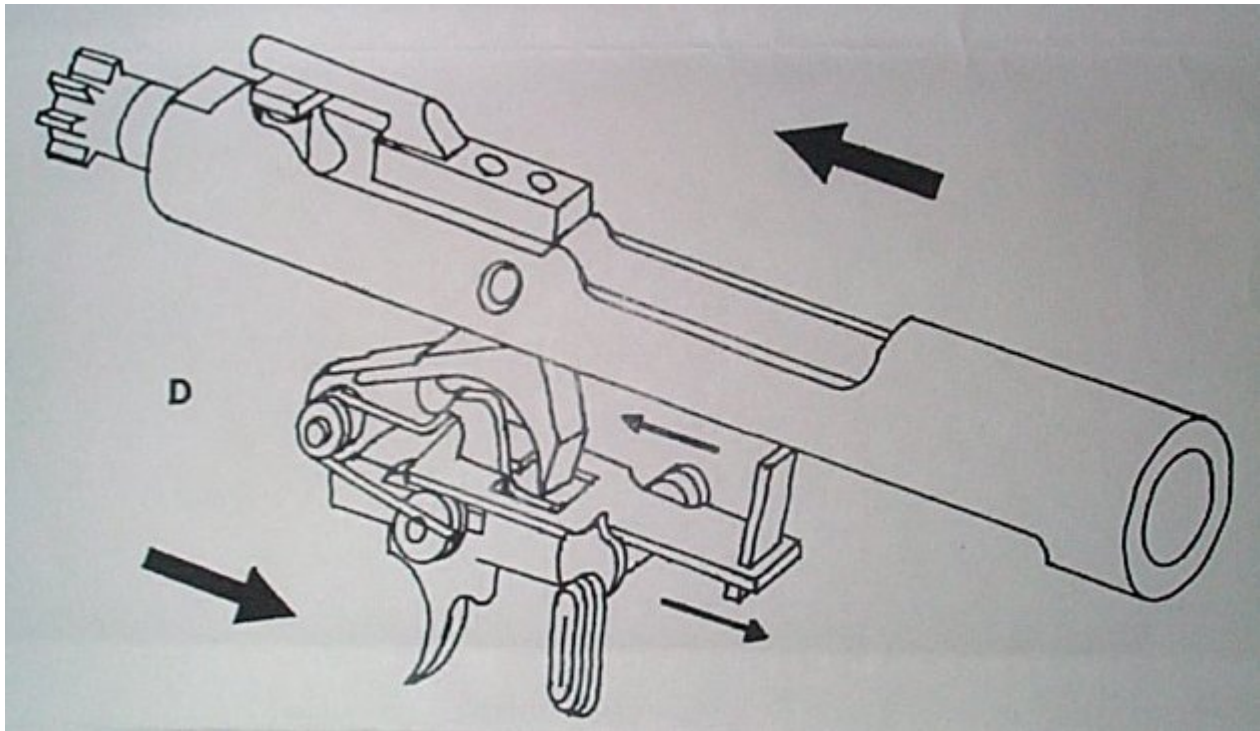

Lightning Link

As long as the trigger is held back, the sear is held below the arc of the hammer notch. The only thing holding the hammer in the cocked position is the disconnecter.

The Lightning Link accomplishes full-auto fire by pulling the disconnecter to the rear forcing it to release the hammer.

The assembled link lays flat in the lower receiver, with the opening at the front fitting over the hook of the disconnecter, and the upright resting between the upper receiver take-down pin post, and the bolt carrier.

In operation the take-down pin post acts as a fulcrum point. When the bolt carrier strikes the top of the links upright the lower end is rocked to the rear, moving the body of the link backward about 1/16 inch, releasing the hammer from under the disconnecter hook. As long as the trigger is held back the rearward movement of the bolt carrier will cock the hammer under the disconnecter hook. The forward movement of the carrier will strike

the upright of the link just as the bolt locks in battery, releasing the hammer, and firing the weapon. When the trigger is released, the sear will stop the hammer in the cocked position negating the operation of the disconnecter and the Lightning Link.

BUILDING LIGHTNING

The drawings show the shape and give the dimensions for a Lightning Link that fits in teh Colt AR-15. If it's to fit in an after market lower reciever it may be necessary to change the outside dimensions. Either way, all that's really important is that it fits inside the reciever and can move back and forth about 1/16 inch.

When building the Lightning Link without a milling machine I find the simpliest way is to cut the long piece to the length and width. Next center punch and drill a 1/8 inch hole at each corner of the large oblong hole at one end. With a dremel tool and banded cutoff wheel cut out the material between the four holes you drilled.

Next center punch and drill a 1/8 inch hole so you can cut out the .130 wide tail that extends out of the oblong you have already cut. NOTE....Do not square off the end of the .130 cut at this time.

Center punch and drill a 1/32 inch hole at each end of the .043 slot at the other end of the part. Cut the slot out with the dremel too and bonded cutoff wheel. Square the ends and finish the slot using a needle file.

Clean up the oblong hole and .130 wide cut with a small file. NOTE....Now's the time to square the end of the .130 cut. CAREFUL....Don't get carried away. The distance between the front {squared end} of the .130 cut and the rear face of the .043 slot can not be any more that 2.120.

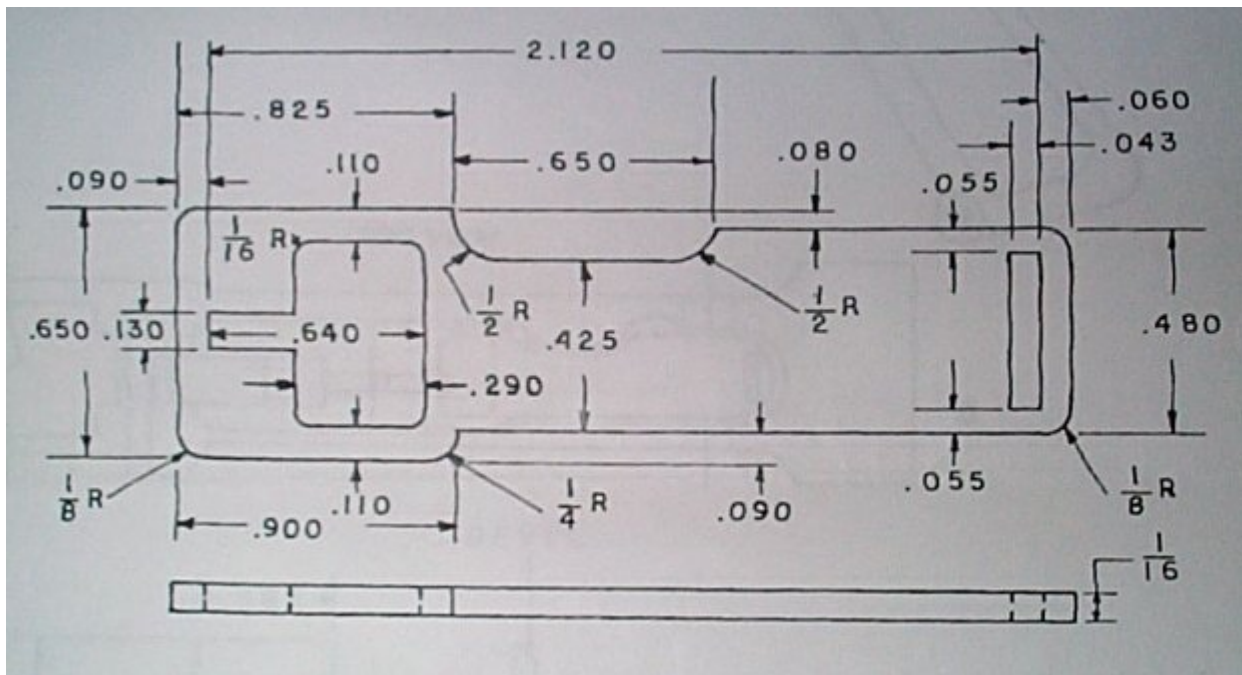

File or grind the outside edges to shape until it fits into the lower reciever without touching the nner reciever walls.

To check the link for fit and function, drop it over the hook on the disconnecter, refer to drawings [A] and [B]. Hold the trigger back and cock the hammer. It will be caught by the disconnecter hook. Now place a scribe or anything that will fit into the slot at the rear of the link and pull it toward the back of the receiver, the hammer should fall. If it did, keep holding the trigger, recock the hammer and do it all again. As long as you hold the

trigger back, the link will release the hammer. When you release the trigger, the link can no longer release the hammer from the cocked position.

If the link would not move back far enough to pull the disconnecter hook off the hammer, find out what's stopping it and correct the problem.

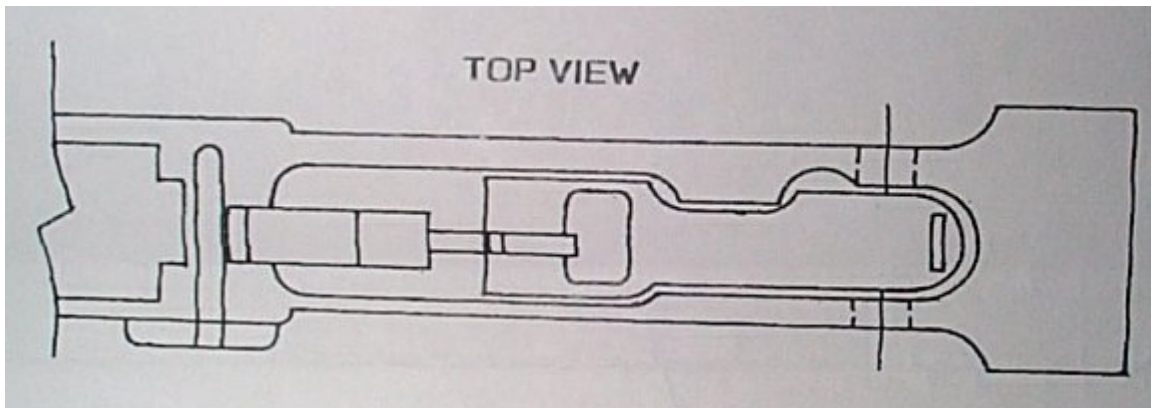
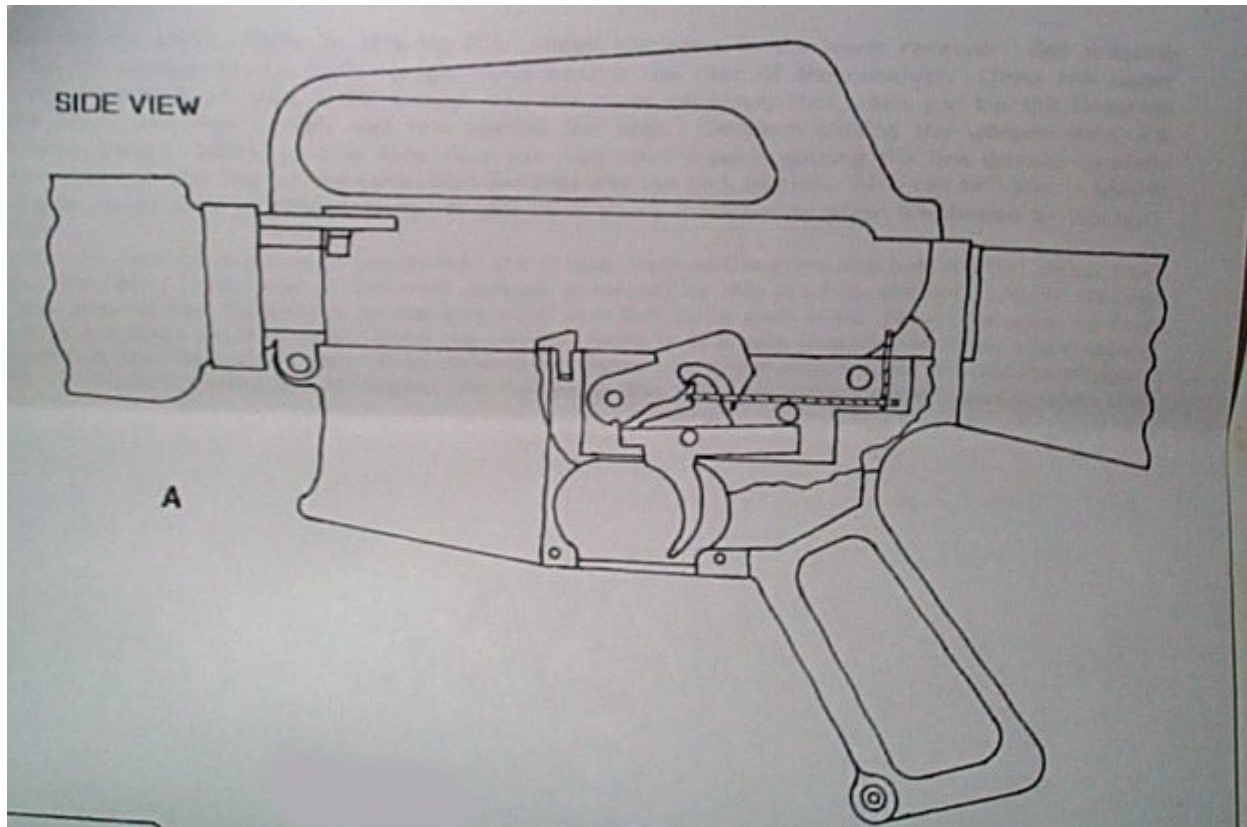

Cut the upright part to length and file or grind it to shape. File a slight bevel at the rear of the upright.

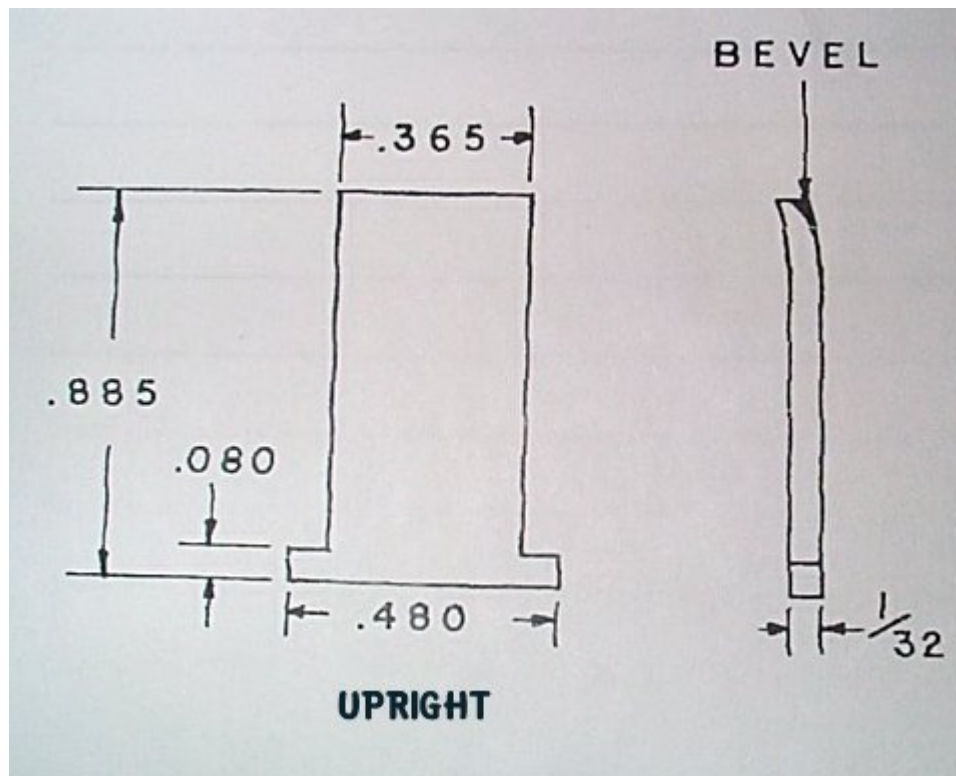

ASSEMBLE THE PARTS

Refer to the first drawing. Install the parts in the lower receiver. See drawing [A]. Tip the weapon so the links upright rests against the rear of the receiver. Close the upper until the take-down pin post is far enough into the lower receiver, that when you tip the firearms muzzle down the links upright can rest against the post. Continue closing the weapon until it's completely closed. NOTE....This first time you may have trouble getting the link upright to slide in place between the rear of the take-down pin post and the bolt carrier. All I can tell you is wiggle and jiggle things until it goes into place. It will fit in place much easier after its shaped by the bolt carrier.

After the take-down pin is in place, hold the trigger back and operate the bolt carrier about five times. The bend in the top of the links upright is formed at this time by the bolt carrier hitting it. See drawing [D]. Be sure to let the bolt slam with full force each time. Now's the time to find out if everything's working right. Cock the weapon, point it in a safe direction and pull the trigger. You should hear the hammer fall. Keep holding the trigger, cock the weapon, and release the trigger. Pull the trigger, nothing should happen, the Lightning Link will have released the hammer when the bolt carrier closed.

TEST FIRE

Load two rounds in the magazine. The first will fire when you pull the trigger, the second will fire automatically. Check the brass for any problems. If all's well, load five rounds and fire. If all goes well, load her up and let her rip.

